



Protection for Feeders,
Generators & Industry

DESCRIPTION

The Current Protection Relay (IPR-A) has been designed to measure the line and ground RMS currents under normal conditions or under disturbances. The current signals are sensed throughout current transformers (CT) from each line. This information is internally processed by the microprocessor in order to take the current protection actions defined under ANSI, IAC or IEC standard.

APPLICATIONS

- Primary and backup protection for utility feeder, power plants and industrial distribution systems.
- Protection of transformers, overhead lines, cables and generators.
- Allow the opening of the switch/disconnector within the limits of its capacity, leaving the circuit interruption fuses in the case of short circuit.

PROTECTION AND FUNCTIONALITY

- **(50)** Instantaneous overcurrent.
- **(50N/50G)** Instantaneous ground overcurrent.
- **(51)** Inverse time phase overcurrent
- **(51N/51G)** Inverse time ground overcurrent
- ANSI, IAC or IEC/BS142 curves included:
 - Moderately inverse.
 - Normal inverse.
 - Very inverse.
 - Extremely inverse.
 - Definite time.
- ***(46)** Negative sequence timed overcurrent
- ***(79)** Reclosing (2 shots)
- Overload alarm pickup level.
- Accumulated kA per phase on breaker interruption.

COMMUNICATION

- Remote communication using a PC or a PLC by 1 RS232 & 2 RS485 ports.
- Remote programming of the setpoints.
- Protocol used: Modbus RTU.

FEATURES

- CT primary ratio selectable in 5 A steps (10 A to 6000 A).
- Line and ground RMS currents measurement.
- 1 trip relay and 2 programmable auxiliary relay.
- Control power drop or internal fault relay.
- Digital inputs: 1 breaker status & 3 programmable
- Touchpad programming
- Breaker operation & trip failure

SIGNALLING

- LED and LCD display indication.
- Phase and ground current indication
- Last trip cause and storage of values
- Indication and storage of fault conditions and their values.
- Threshold LED for 50/50N, 51/51N.

ADDITIONAL FEATURES: (on request)

- 3 Setpoints Group for Phase & Ground Protections
- Autoreclose with 2 shoots
- Cold load pickup control

APPLICABILITY

<i>Systems:</i>	Mono phase and 3 or 4-wire three-phase system
<i>Frequency</i>	50 and 60 Hz
<i>Voltage:</i>	69 kV maximum

(*) IPR-A2 version only



Quality certified ISO 9001:2000

Protection relay
IPR-A_GBBR_180315

SPECIFICATIONS

SUPPLY VOLTAGE 24÷310 Vdc, -15%, +10% 24÷240 Vac, -15%, +20% 50/60Hz	MAX. POWER CONSUPTION 12VA (7W)
TEMPERATURE RANGE Operational: 0 °C a +50 °C Storage: -20 °C a + 70 °C	RELATIVE HUMIDITY Max. 90% (non condensing)
DIELECTRIC WITHSTAND VOLTAGE 2 kVac, 60 s	BURN IN 48 hours at 50 °C
CONSTRUCTION According to VDE, UL, CEI norms.	OUTPUT CONTACT Rated load: 8A DC 150W resistive or 90W inductive (L/R=40 ms) AC 2000VA resistive or 800VA inductive (PF=0.4) Max. operating Voltage: 250 Vac, 125 Vdc
COMMUNICATIONS Type: 1 RS232 port + 2 RS485 ports, Half duplex, 1200 → 19200 baud Protocol: Modbus RTU Functions: Read/Write setpoints Read actual values Execute commands	LED INDICATORS Relay status: Trip Alarm Out of Service System status: Breaker closed, Breaker open, breaker earthed, pickup 50, pickup 51, pickup 50N/G, pickup 51N/G. Display (LCD): 16 x 2 digits
DIGITAL INPUT Type: Dry contacts only, 500 Ohm Max. ON resistance (12 Vdc @ 10 mA provided by relay)	TERMINAL BLOCK Fixed, back connection terminals with 4-mm ² -section cable (10 AWG).
FRAME In ABS auto-extinguish with frontal in polycarbonate (IP54).	ASSEMBLY The relay has to be fixed to the structure with the help of stirrups and screws.
DIMENSION 144 x 144 x 141 mm WEIGHT 1.5 Kg	FRONT PANEL CUTOUT 137 x 137 mm
PHASE AND GROUND CT INPUTS Source CT (In): CT (In) 5 A to 6000 A, Steps: 5 A. CT secondary: CT 1 A or 5 A (specified when ordered). Sampling: True RMS, 16 sample/s. CT burden: 0.25 VA per phase at rated secondary current. Continuous: 2xIn. Current withstand capac.: 20 times In for 1 sec. Accuracy: at ≤ 1xCT => ± 0.5% of 1xCT at > 1xCT => ± 0.5% of 20xCT	PHASE TIME OVERCURRENT Pickup level: 4% to 300% of CT, steps of 1% Time multiplier: 0.1 to 20.0 for each shape curve Reset: Time reset to zero each time current level falls below pickup threshold. Accuracy: Pickup: ±3% of setting. Time: ±3% of trip time or ±20 ms
INSTANTANEOUS PHASE OVERCURRENT Pickup level: 4% to 1800% of CT, steps of 1% or 10% Delay time: 0 to 2000 ms, steps of 10 ms Accuracy: Pickup: ±3%. Time: +35ms max	GROUND TIME OVERCURRENT Pickup level: 4% to 300% of CT, steps of 1% Time multiplier: 0.1 to 20.0 for each shape curve Reset: Time reset to zero each time current level falls below pickup threshold. Accuracy: Pickup: ±3%. Time: ±3% of trip time or ±20 ms
INSTANTANEOUS GROUND OVERCURRENT Pickup level: 4% to 1800% of CT, steps of 1% or 10% Delay time: 0 to 2000 ms, steps of 10 ms Accuracy: Pickup: ±3%. Time: +35ms max	TIME OVERCURRENT CURVES Phase and Ground: ANSI, IAC or IEC Moderately Inverse, Normally Inverse, Very Inverse Extremely Inverse, Definite Time

MODALITA DI COLLEGAMENTO CON TOROIDI
CURRENT TRANSFORMER CONNECTIONS TYPES

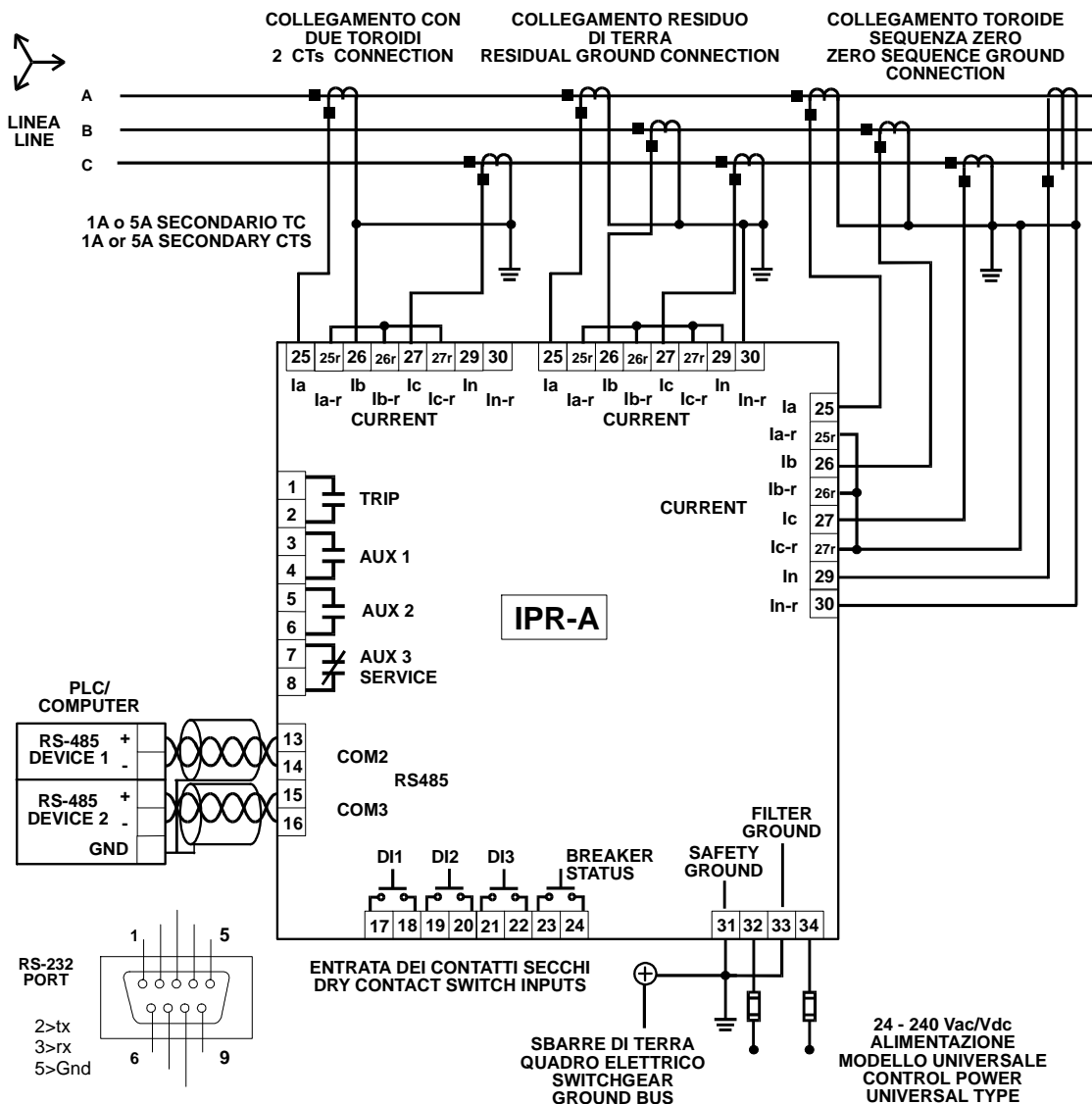

ORION ITALIA Srl

Via G. Orsi 35, 29100 Piacenza [PC] - Italia

Phone: + 39 0523591161 - Fax: + 39 0523593898 - www.orionitalia.com



Quality certified ISO 9001:2000