

# GEPA ARG-24L Battery Charger and Battery Group User Guide

## 1. General



GEPA ARG-24L Series Battery Charger & Battery Group is used for DC power systems of power stations, substations or other applications where DC voltage needed. Device provides DC voltage to system by rectifying AC voltage input and keeps batteries under charge (float charge) in case of AC power loss to keep DC power bus alive.

GEPA ARG-24L Series Battery Charger & Battery Group is designed for applications which require short-term high current demand. The device designed considering the requirements of substations. **Provides short-term high current demand, for like circuit breaker charging motor, and continuously provides float charge voltage for battery group and DC power system.** Thus, it provides low-cost and ergonomic solution for such applications.



- Read this document before montage and wiring.
- Make sure device is not energized before wiring.
- Do not touch terminals while device is energized.
- Montage and wiring must be done according to document by qualified person/people.
- Use dry cloth to clean. Do not use chemicals that may lead deformation or corrosion.
- Warranty is valid for 2 years from invoice date, batteries are excluded from warranty.
- Warranty will be violated under these conditions; unauthorized modifications, opening enclosure and removing warranty label.
- This device is intended for use in indoor and industrial environment.
- Manufacturer or sales company is not responsible of faults if user doesn't obey recommendations at the above.



Batteries are not under warranty.



Transformer in the device may cause inrush currents. C type fuse at AC supply voltage input is recommended.



Contact with high voltage ( $\geq 42.2V_{ACpeak}$  or  $\geq 60 V_{DC}$ ) may cause electrical shock and injury.



This product conforms to Low Voltage Directive (LVD) 2014/35/EU and Electromagnetic Compatibility (EMC) Directive 2014/30/EU. Conformity is assessed in accordance to the latest versions of EN 61204-7 and EN 61204-3 standards.



Consult us for recycling or disposal of the device and batteries according to WEEE directive.

## 2. Features

- Ergonomic and low-cost solution for power stations and substations
- Thyristor controlled rectifier
- Continuous 5A, short-term 15A output current
  - Output voltage is adjustable in range of 20 – 30  $V_{DC}$  with 0.1  $V_{DC}$  steps
  - Continuous output current is adjustable in range of 1 – 5 A with 0.1 A steps
  - Short-term output current is 15 A
- Soft start
- Electronic short-circuit protection at DC output
- VRLA type 5 or 10 years life expectancy batteries
- Output voltage and current is adjustable via control unit
- Output voltage and current measurement on control unit
- Alarm contact output for SCADA system connection

### 3. Montage and Wiring

- Please read instructions and markings before montage.
- Mount the device on the wall and screw from montage holes to fix.
- Make sure device is not energized before making connections.
- Check cable current carrying capacity for maximum requirements.

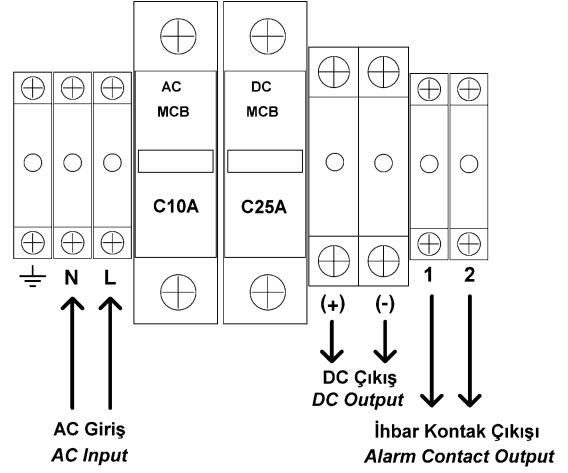

### 4. Usage

#### 4.1. Turn On and Off

Device may turn on after proper montage and wiring.

To turn on, follow these steps:

1. Switch AC MCB position to ON
2. Switch DC MCB position to ON

To turn off, follow these steps:

1. Switch DC MCB position to OFF
2. Switch AC MCB position to OFF

#### 4.2. Control Unit and Settings

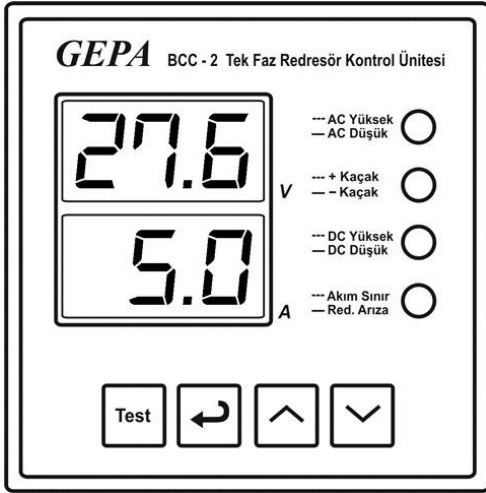

GEPA ARG-24L Series Battery Charger & Battery Group's control unit, BCC-2 Control Unit, provides human machine interface.

Output voltage and current is adjustable; output voltage and current live measurements and alarm indicators are available through control unit.

To adjust settings parameters follow steps at the below:

1. Press button.
2. Voltage display blinks. It displays adjusted voltage output value. Press up or down buttons to adjust.
3. Press button again to save new parameter.
4. Current display blinks. It displays adjusted float current output limit value. Press up or down buttons to adjust.
5. Press button again to save new parameter.



In case of high current demand –like deep discharged battery group or any device requires high current– output voltage might be lower than adjusted.

Device can display battery group voltage without AC supply voltage. Press **Test** button to make the device to display battery group voltage while AC supply voltage not applied.

#### 4.3. Alarm Function

Device has an alarm contact output. NO alarm contact trips in case of:

- High(240 V<sub>AC</sub>) or low(190 V<sub>AC</sub>) AC supply voltage
- High(30 V<sub>DC</sub>) or low(20 V<sub>DC</sub>) DC output voltage
- Leakage between DC output and earth
- Output current is higher than adjusted output current value

## 5. Order Code

**ARG – 24 L 05 26**

Output Voltage	Output Current	Battery Capacity
24: 24 V 110: 110 V	05: 5 A 10: 10 A 20: 20 A N: N A	7: 7 Ah 18: 18 Ah 26: 26 Ah N: N Ah

Example order codes:

- ARG-24L0526: 24V/5A output, short-term 15A current output, 26Ah battery group capacity
- ARG-24L0518: 24V/5A output, short-term 15A current output, 18Ah battery group capacity

## 6. Technical Specifications

Specifications table at the below is ARG-24L0526 model. Other models' specification table will be placed in the device.

<b>Input Voltage</b>	230 V <sub>AC</sub> (±%20), 50Hz(±%5)	
<b>Input Current</b>	1.5 A <sub>max</sub>	
<b>Power Factor</b>	0.63 <sub>min</sub>	
<b>Output Voltage</b>	<b>Nominal</b>	27.6 V <sub>DC</sub>
	<b>Range</b>	20.0 – 30.0 V <sub>DC</sub> (0.1V step)
	<b>Ripple</b>	≤% 5
<b>Output Current</b>	<b>Continuous</b>	1.0 – 5.0 A (0.1A step)
	<b>Short-Term</b>	15 A (30s)
<b>Output Power</b>	140 W <sub>max(continuous)</sub>	
<b>Output Filter</b>	L – C filter	
<b>Efficiency</b>	>% 70	
<b>Cooling Method</b>	Natural convection	
<b>Operating Temperature</b>	(-25) – (+55) °C	
<b>Storage Temperature</b>	(-30) – (+60) °C	
<b>Relative Humidity</b>	<%95 RH(w/o condensation)	
<b>Pollution Degree</b>	III	
<b>Alarm Contact Output</b>	NO dry contact, 1250VA / 150W 5A/30V <sub>DC</sub> or 5A/250V <sub>AC</sub> capacity	
<b>Applied Standards</b>	IEC 61204-7:2006 (PS-E) [LVD], IEC 61204-3:2011 (Industrial) [EMC], IEC 60146-1-1:2009 [Informative]	

## 7. Dimensions

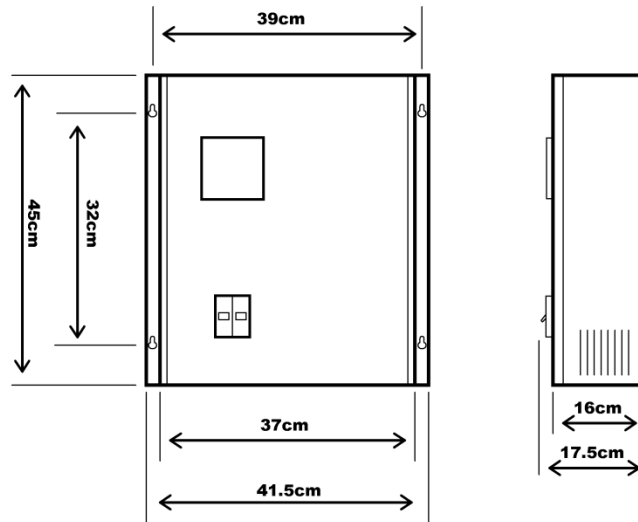

**GEPA**

GEPA Elektronik San. ve Tic. Ltd. Şti.  
Büyük Sanayi 1. Cad. No: 93/36 İskitler Altındağ/ANKARA  
Tel: +90 (312) – 341 – 4104 • Fax: +90 (312) – 384 – 0436  
www.gepaelk.com • gepa@gepaelk.com

Rev.0; 3/17